

STANDING SEAM WELDED END LAP

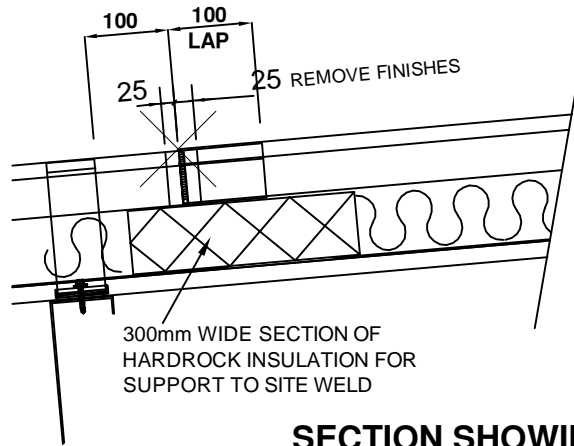

SECTION SHOWING SHEET LAP

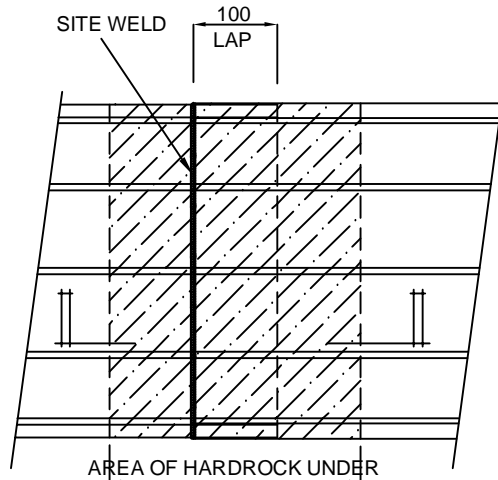

PLAN VIEW OF SITE WELDED LAP

NOTE:
FINISHES TO TOP SHEET TO BE REMOVED FROM FRONT AND BACK OF SHEET FOR 25mm EITHER SIDE OF WELD ZONE TO PREVENT CONTAMINATION OF WELD

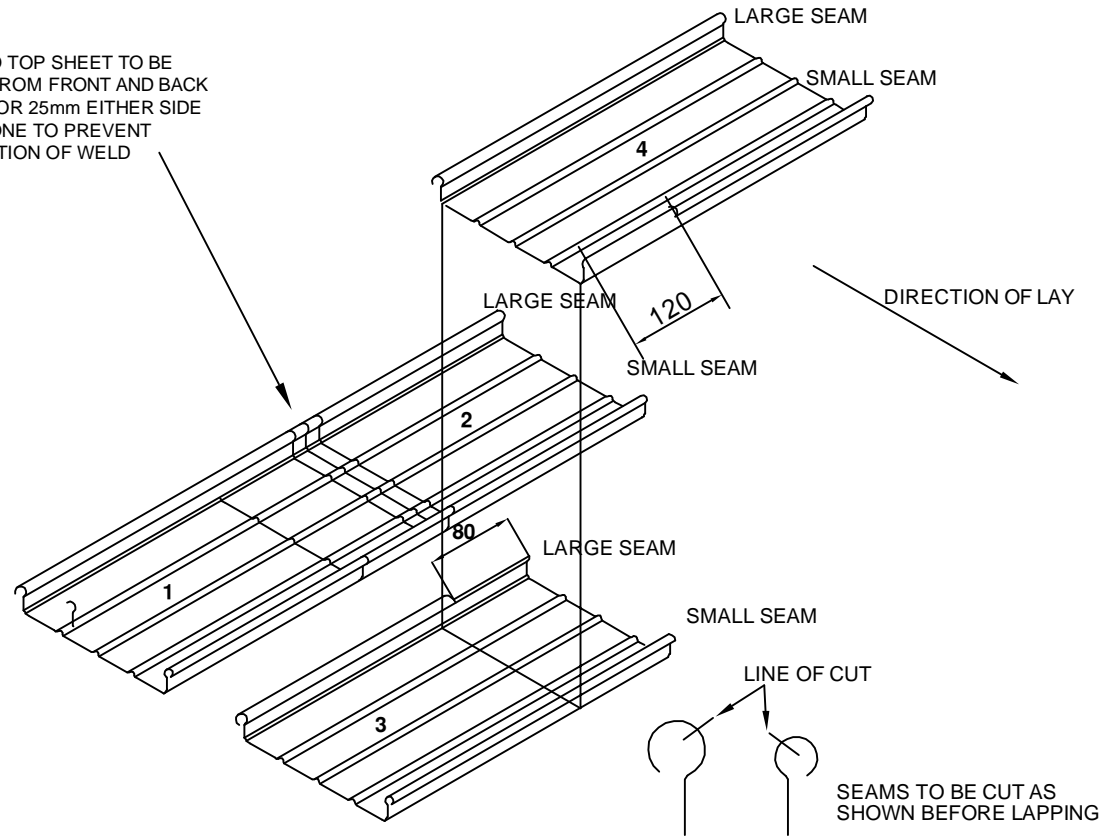

EXPLODED ISOMETRIC VIEW OF LAP DETAIL

PROJECT

-

PROJECT No

-

CLIENT

-

DRG.NUMBER

S/009

DATE

-

DRAWN BY

DARREN POWELL

Sureweld & Roof Ltd

Ball Mill Top
Hallow
Worcester
WR2 6LS

Tel 01905 641104

Fax 01905 641135

e mail : sales@sureweld.com